

# Design and Fabrication of Intelligent Pneumatic Braking System for Automobiles Using Ultrasonic Sensor

Dr. Tejinder Sharma \* Sanjeev Kumar Sharma \*\*

\*Associate Professor, Department of Commerce, Kurukshetra University, Kurukshetra

\*\*Associate Professor, Department of Commerce, DAV College, Jalandhar

## ABSTRACT

The Indian knitwear manufacturers need to think beyond the factor driven sources of competitive advantage and develop market oriented competences. It calls for developing strong brands, associating them with their distinctive personality and positioning them appropriately into the consumers' perceptual space. The paper studies the project brand personality of 100 the knitwear brands manufactured in Ludhiana and its intended positioning into the consumers' perceptual space. Findings show the emergence of five broad factors encompassing the projected brand personalities. Various knitwear brands have been positioned according to the emerging projected brand personalities.

**Key words:** Branding Strategy, Brand orientation, Lead Brand, brand positioning, Cluster.

## 1. Introduction

As safety is the prime concern for the automobile industries, many technologies are working for it to ensure the safety of passengers, vehicle and surrounding. If we consider the traffic accidents in

India during previous years, the numbers are on the rise which in itself a prime concern for this industry. The figure 1 shows the traffic accidents in India during previous years<sup>1</sup>.

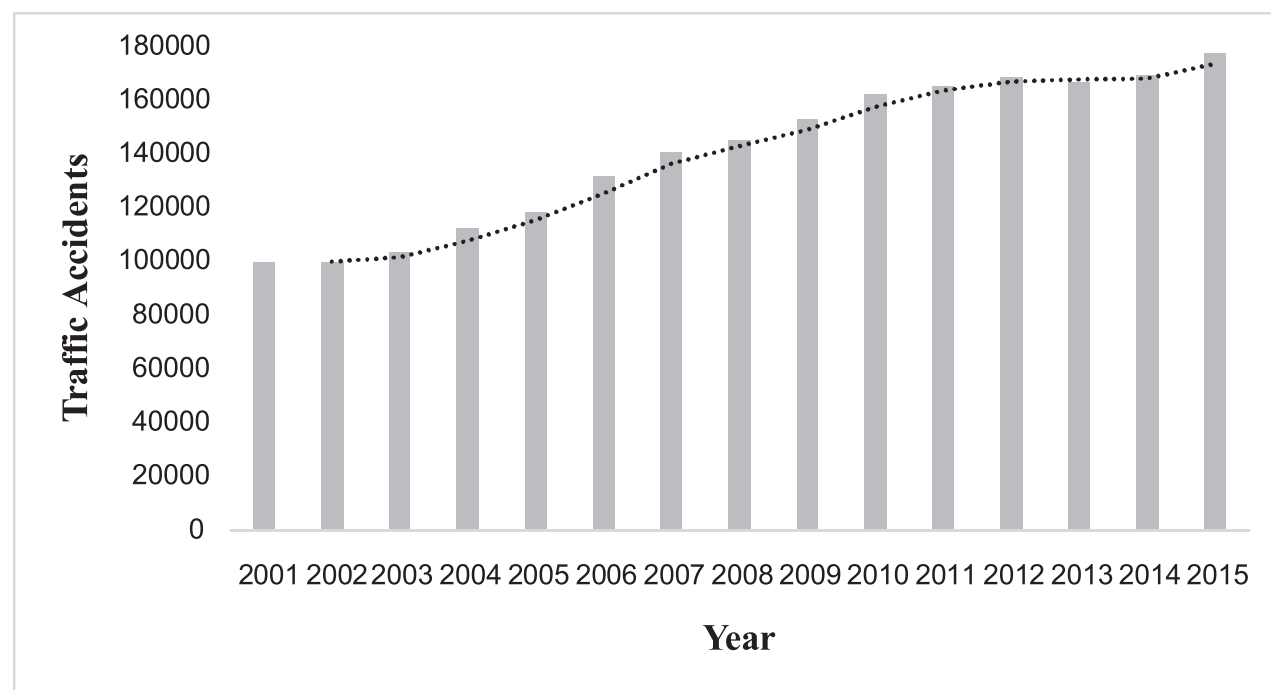

Figure1. Year wise traffic accidents in India

Insufficient braking is one of the most dominating reason for traffic accidents. It was found that out of these accidents, 20- 30% occurs while reversing a vehicle. During parking or reversing a vehicle driver is unable to see what is behind the vehicle and eventually vehicle strike with the obstacle behind. Now a days cars are equipped with the alarm system which trigger alarms when the car gets too close to an object but in this system also driver need to be attentive while applying the brakes. So the motive of this research is to enhance this already available facility with addition of automatic braking system.

A literature survey of previous work<sup>2-6</sup> reveals that very less work has been done on autonomous braking system and this need to be explored in detail. So, in this research work, an attempt is made to design & fabricate an intelligent pneumatic braking system which automatically apply brakes when vehicle approaches an obstacle. This sensor operated intelligent braking system consists of ultrasonic transmitter- receiver circuit, control unit and pneumatic braking system. The ultrasonic sensor is employed to detect the obstacle and send signal to the control unit for appropriate braking action.

## 2. Materials& Method

### 2.1. Material Used

This section deals with the various components used

in this automatic braking system:

#### 2.1.1. Control Unit

The control unit is a component that control the operation of the processor. It operates the input and output devices according to program instructions. Arduino Uno is used as a control unit. It is a microcontroller board based on the ATmega328P having 14 digital input/output pins out of which 6 can be used as Pulse Width Modulation (PWM) outputs and remaining 6 as analogue inputs. It includes a 16 MHz quartz crystal, a USB connection, a power jack, an ICSP header and a reset button.

#### 2.1.2. Solenoid Valve

A solenoid valve is an electromechanical device which uses an electric current to generate a magnetic field and thereby operate a mechanism which shutoff, release distribute or mix fluids depending on the application. Solenoid valves are fast, highly reliable, having long service life & low control power and compact design.

#### 2.1.3. Directional control valve

Directional control valves (DCV) are one of the most important control element in hydraulic as well as pneumatic system that controls the fluid flow. 5/2 DCV 1- 2, 4- 5 solenoid actuated, spring reset is employed in this research work. Figure 2 shows the block diagram of the used DCV.

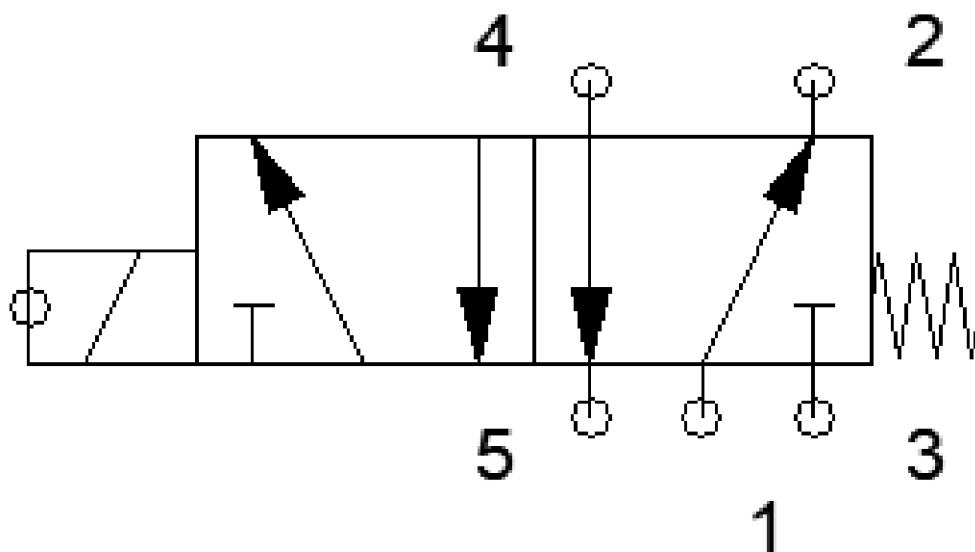

Figure 2. Block diagram of DCV

#### 2.1.4. Ultrasonic Sensor

HC-SR04 Ultrasonic sensor was used in this research work. It consist of 4 pin module having pin names; Vcc, Trigger, Echo and Ground respectively. The specification of sensor are: Operating voltage- +5V, Theoretical Measuring Distance- 2cm to 450cm, Practical Measuring Distance- 2cm to 80cm, Accuracy- 3mm, Measuring angle covered- <math><15^\circ</math>, Operating Current- <math><15\text{mA}</math> and Operating Frequency- 40Hz.

#### 2.1.5. Double Acting Cylinder

Two double-acting pneumatic cylinders were used in the research work. The specifications of cylinders are: Brand – TECHNO, Model Number- MAL 25x100, Bore- 25mm and stroke- 100mm.

#### 2.1.6. Compressor

Compressor is a supply element of pneumatic system

which compresses and transports the air throughout the system. A portable air compressor of make- Creative VIA with a maximum operating pressure of 10bar was used in this research work.

### 2.2. Methods

#### 2.2.1. Experimental setup

Rectangular hollow structural sections were used to make the frame of the experimental setup. Four bicycle wheels were connected to the frame to make it moveable. All the components viz. control unit, solenoid valve, sensor, pneumatic cylinder and compressor were mounted on the frame. DC powered wiper motor was used to drive the front wheel and 12V battery was employed to power the electronic devices. These complete processes are electronic based which required electric supply. Figure 3 shows the actual layout of experimental setup.

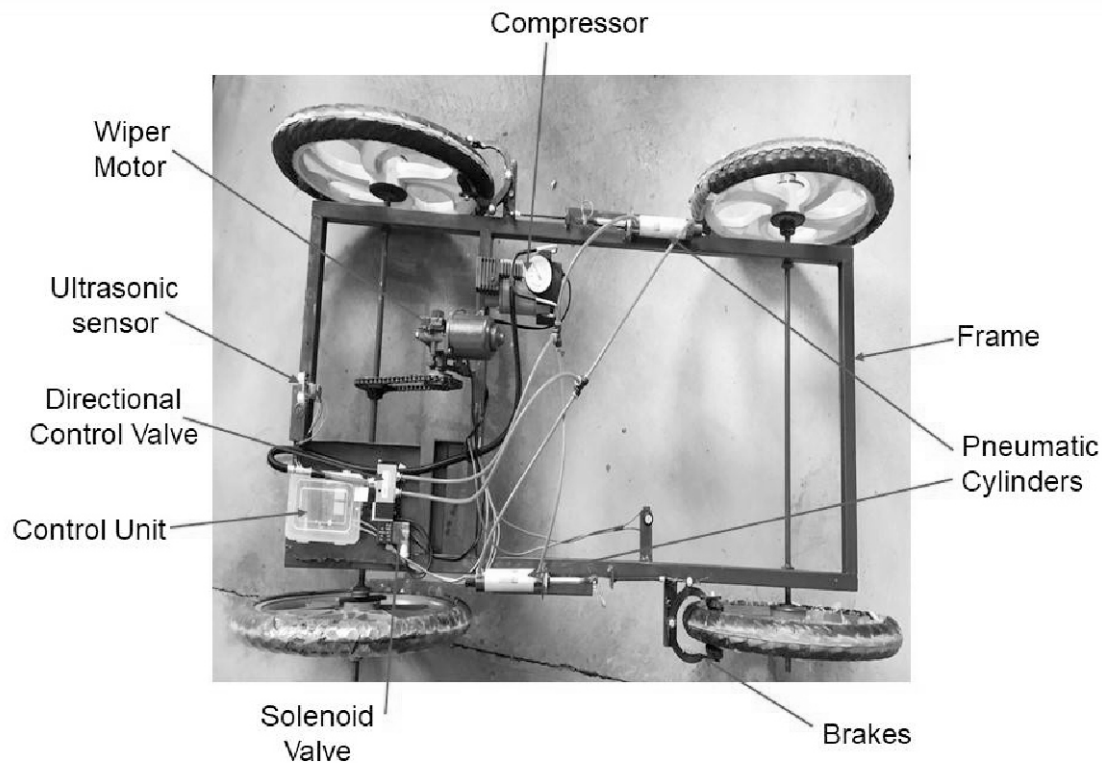
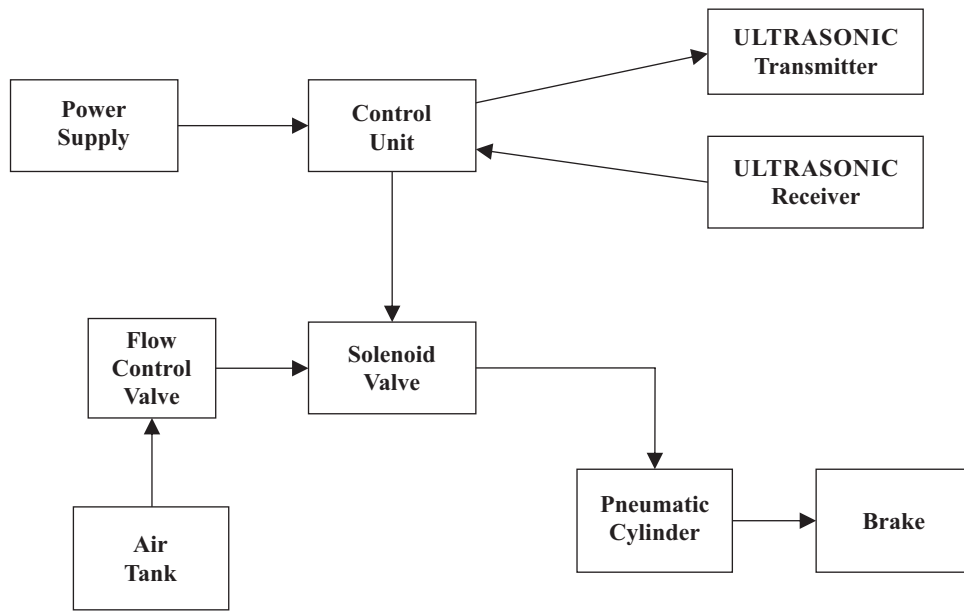

Figure3. Experimental setup

#### 2.2.2. Working principle

Ultrasonic sensor consists of a transmitter and a receiver. The transmitter continuously transmits ultrasonic waves and presence of any obstacle makes the ultrasonic waves to reflect back which in turn is received by the ultrasonic receiver. On receiving the

reflected signal, it gives the impulse to the control unit. The control unit actuated the solenoid valve which commands the directional control valve and brake is applied with the help of pneumatic cylinders. Figure 4 shows the block diagram of setup and figure 5 shows the pneumatic circuit employed in experimental setup.



**Figure 4. Block diagram of experimental setup**

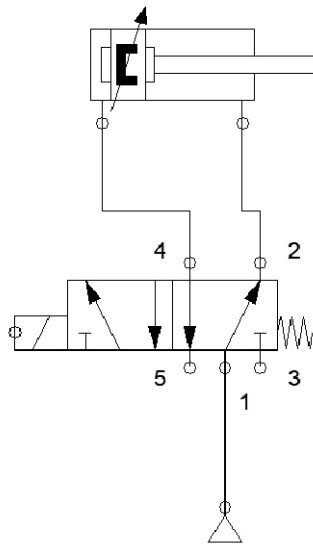

**Figure 5. Pneumatic braking circuit**

## 1. Results and Discussion

The stopping distance or braking distance is the most important factor in designing a braking system. Braking distance for a particular speed

is the distance between the point of application of the brakes and the point at which the vehicle comes to a complete stop from the present speed. It is calculated by using following formula:

$$\text{Braking Distance} = \frac{v^2}{2\mu g} \text{ meter}$$

Where, v= Speed of the vehicle (m/s)

$\mu$  = Coefficient of friction of road

g = Acceleration due to gravity = 9.81(m/s<sup>2</sup>)

In this formula coefficient of friction  $\mu$  is taken as 0.8 considering ideal condition of brakes and the road.

The table 1 shows the theoretical and actual braking distance at various speed.

**Table 1.** Theoretical and experimental braking distance with speed

S. No.	Vehicle speed, km/hr	Theoretical braking distance, m	Experimental braking distance, m
1	60	17.7	28.16
2	50	12.5	17.7
3	40	7.8	9.5
4	30	4.43	3.5
5	5	0.12	0.16

## 4. Conclusion

Most of the road accidents results from the fault of driver and not timely braking. This sensor based braking system in addition to the conventional braking system provide safety and helps in reducing the number of road accidents. If this intelligent pneumatic braking system is combined with other safety technologies such as disk brake, antilock braking system etc. it really improves the safety of passengers as well as prevent the occurrence of road accidents.

## 5. References

1. Accidental Deaths and Suicides in India' Report (2016) National Crime Records Bureau, Ministry of Home Affairs. <http://mospi.nic.in/statistical-year-book-india/2017/207> (accessed November 15, 2018)
2. Hemalatha, B. K., Pooja, Chaithra, M., Megha, Rakshitha, R. T. (2016) Automatic Braking System

for Automobiles Using IR Sensor. *International Journal of Advanced Research in Electrical, Electronics and Instrumentation Engineering*, 5(5), 4342-4348.

3. Gopal, P. G., Shruti, V. G., Zariye, A., Sagar, Ritpurkar, P. (2014) Review of speed control and automatic braking system. *International Journal of Engineering Research & Technology*, 3(2), 474-476.
4. Dhanya, K. R., Jeyanthi, R. (2012) Automatic braking system with sensor fusion concept. *IJEEES*, 4(1), 23-27.
5. Anusha, P. V. (2015) Collision control and collision avoidance using ultrasonic sensor. *International Journal Of Current Engineering And Scientific Research*, 2(7), 2393-8374.
6. Ingle, R., Thak, S., Shelke, A. (2014) Automated reverse braking system. *International Journal of Engineering Sciences & Research Technology*, 3(4), 6095-7001.